



Overflow valve for liquids and gases
up to 80 / 130 / 150 °C

Technical Data

Connection	G 1/2 - 2
	DN 15 - 50
Nominal Pressure	PN 10 - 16
Inlet Pressure	up to 2 - 16 bar
	in 3 setting ranges
K_{VS} -value	3.5 - 5.5 m ³ /h
Tightness	acc. VDI/VDE-guideline 2174
	(leakage rate \leq 0.05 % of K_{VS} -value)
Surface Roughness	\leq 3.2 μ m

Description

Medium-controlled overflow valves are simple control valves offering accurate control while being easy to install and maintain. They control the pressure upstream of the valve without requiring pneumatic or electrical control elements.

The UV 3.8 overflow valve is a spring-loaded piston-controlled proportional control valve designed for hygienic applications and medium volumes. The valve cone is fitted with a hard seal.

This bypass valve is manufactured from deep-drawn stainless steel featuring excellent corrosion resistance. It contains virtually no dead pockets and is suitable for use in CIP and SIP systems. The angled design allows complete draining.

The spring module comprising bonnet, spring, setting spindle, diaphragm and internal components, is connected to the valve body only by means of a clamp ring and two bolts. Changing the diaphragm or the complete spring assembly for a different control pressure range is extremely simple and does not call for special tools. The same applies to servicing and maintenance. Changing the control pressure setting does not affect the height of the valve (non-rising setting spindle).

The inlet pressure to be controlled is balanced across the piston by the force of the valve spring (set pressure). If the inlet pressure rises above the set pressure, the valve opens. With decreasing inlet pressure the valve control orifice reduces, when the pipeline is depressurised the valve is closed. Rotating the adjusting screw clockwise increases the inlet pressure.

The UV 3.8 overflow valve does not require a pilot line.

STANDARD EQUIPMENT

- All stainless steel construction
- Piston control

OPTIONS

- Polished version for food, pharmaceutical and superclean applications, surface roughness $R_a \leq$ 0.25 or 0.4 or 0.8 μ m
- For toxic or hazardous media: sealed bonnet complete with leakage line connection (incl. sealed adjusting screw). Must be installed with a leakage line capable of draining leaking medium safely and without pressure
- Various diaphragm and seal materials suitable for your medium
- Special connections: Aseptic, ANSI or DIN flanges, welding spigots; other connections on request
- Special versions on request

Operating instructions, Know How and Safety instructions must be observed.

The pressure has always been indicated as overpressure.

We reserve the right to alter technical specifications without notice.

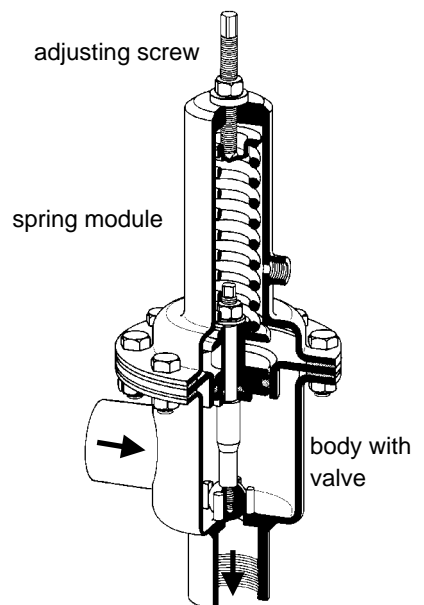
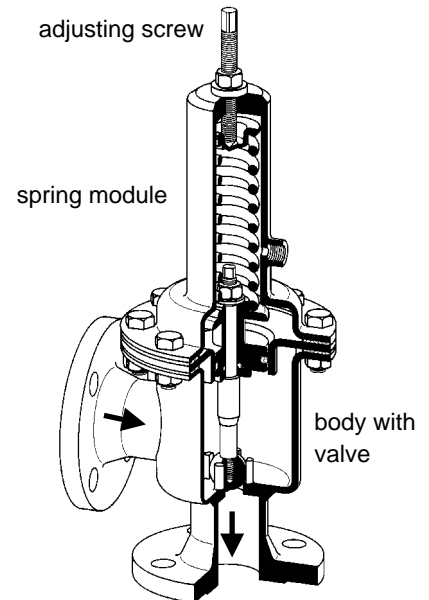

K_{VS}-values [m³/h]					
nom. pressure	DN	25	32	40	50
	G	1	1 1/4	1 1/2	2
K_{VS} -value		3.5	3.5	5.5	5.5

Setting Ranges [bar], Nominal Pressure		
2 - 5	4 - 10	8 - 16
PN 10	PN 16	PN 16

Overflow valve for liquids and gases
up to 80 / 130 / 150 °C



Materials			
Temperature	80 °C	130 °C	150 °C
Body	CrNiMo-steel	CrNiMo-steel	CrNiMo-steel
Bonnet	steel welded optional CrNiMo-steel		
Spring	spring steel C optional CrNiMo-steel		
O-ring	NBR	EPDM optional FPM	FPM-PTFE coated

Dimensions [mm]				
size	nominal diameter DN			
		25	32	40
A	100	105	115	125
B	100	105	115	125
C	500	500	500	500
ø D	175	175	175	175

Dimensions [mm]				
size	nominal diameter G			
		1	1 1/4	1 1/2
A	80	80	80	80
B	80	80	80	80
C	500	500	500	500
ø D	175	175	175	175

Weights [kg]				
nominal diameter DN	25	32	40	50
		10.2	11.5	12

Weights [kg]				
nominal diameter G	1	1 1/4	1 1/2	2
		8.5	8.8	9

Special designs on request.
The pressure has always been indicated as overpressure.
Mankenberg reserves the right, to alter or improve the designs or specifications of the products described herein without notice.

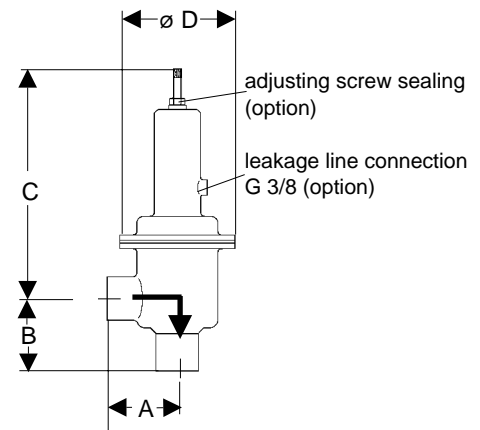
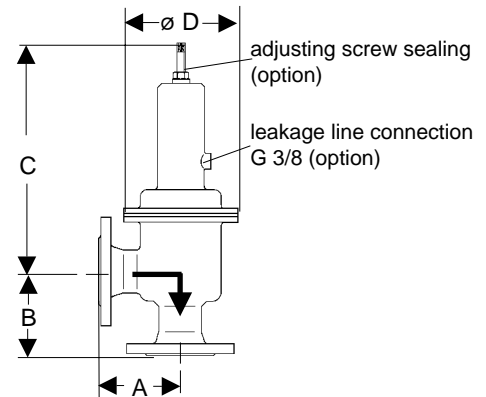

Recommended Installation

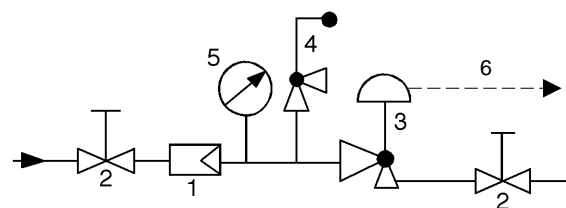

- 1 Strainer
- 2 Shutoff Valves
- 3 Overflow Valve
- 4 Safety Valve
- 5 Pressure Gauge
- 6 Leakage Line G3/8 (option)

use MANKENBERG-products

WIR REGELN DAS SCHON
FIRMLY IN CONTROL

MANKENBERG