



Filter for steam, gases and corrosive media up to 190 °C

Technical Data

Connection	G 1/2 - 2 DN 15 - 50
Nominal Pressure	PN 16

Description

Filters are used to retain contaminants present in fluids. F 6.06 is entirely manufactured from deep-drawn stainless steel featuring excellent corrosion resistance. For this reason it is used for the filtration of corrosive gases and liquids.

Top and bottom sections of the body are connected by a clamp ring and 2 bolts. Servicing/maintenance is easy and does not call for special tooling.

Two different types of tube filters can be fitted in the filter body.
 Type P: High quality pleated 3-ply filter element (fabric/metallic fibre fleece/ fabric)
 Type S: Filter element made of sintered stainless steel

Low pressure loss and large dirt retention capacity ensure long life and minimise servicing and maintenance.

The filter may be cleaned by blowing-through with compressed air or steam or flushing-through using a suitable cleaning agent. The best results are obtained by ultrasonic cleaning in an aqueous solution.

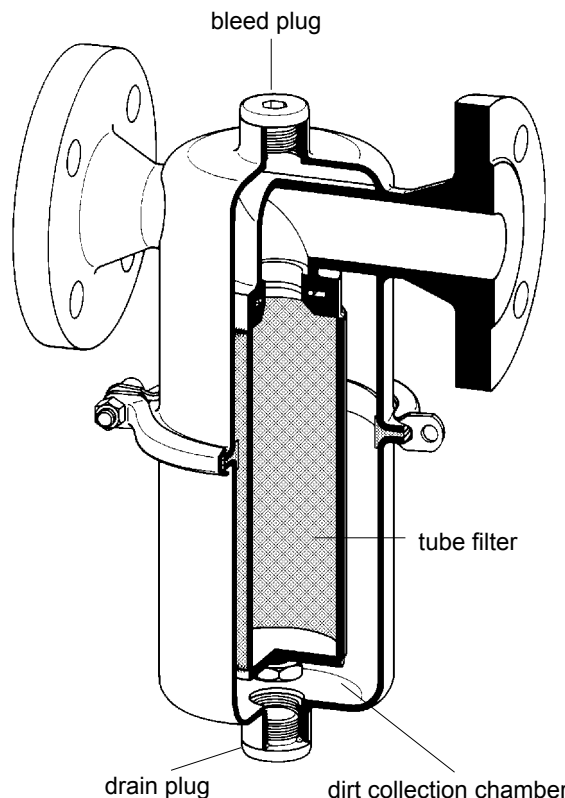

STANDARD EQUIPMENT

- All stainless steel construction
- Quick-release body clamp ring
- Retained particle size: type P - 25 µm; type S - 20 µm
- Drain plug in body bottom section
- Bleed plug in body top section

OPTIONS

- Retained particle size 5 µm for types P and S
- Various seal materials suitable for your medium
- Special connections: Aseptic, ANSI or DIN flanges, welding spigots; other connections on request
- Special versions on request

Operating instructions, Know How and Safety instructions must be observed.

The pressure has always been indicated as overpressure.

We reserve the right to alter technical specifications without notice.

Resistance Coefficient ζ			
filter element type	particle size μm	nominal diameter	
		G 1/2 - 1 1/4 DN 15 - 32	G 1 1/2 + 2 DN 40 + 50
P	25	15	13
	5 (option)	17	16
S	20	16	15
	5 (option)	28	25

Max. permitted Pressure Drop [bar]			
design		nominal diameter	
		G 1/2 - 1 1/4 DN 15 - 32	G 1 1/2 + 2 DN 40 + 50
P	5/25 µm	16	5
	5 µm	12	11
S	20 µm	8	7

Calculating the pressure drop

$$\Delta p = \zeta \cdot \omega^2 / 2 \cdot \rho \cdot 10^{-5} \text{ [bar]}$$

- ζ resistance coefficient (see table)
- ω [m/s] flow velocity within the connection cross section (nominal diameter)
- ρ [kg/m³] density of fluid

Filter for steam, gases and corrosive media up to 190 °C



Materials		
Design	P	S
Body	CrNiMo-steel	CrNiMo-steel
Seal	FPM-D	FPM-D
Filter Element	CrNiMo-steel, EP	1.4404
Profile Clamp	CrNiMo-steel	CrNiMo-steel

Dimensions [mm]						
size	nominal diameter G					
	1/2	3/4	1	1 1/4	1 1/2	2
A ₁	160	158	156	204	192	192
B	235	235	235	235	350	350
C	275	275	275	275	420	420
D	140	140	140	140	200	200
E	G 1/4	G 1/4	G 1/4	G 1/4	G 1/4	G 1/4

Weights [kg]						
nominal diameter G						
1/2	3/4	1	1 1/4	1 1/2	2	
3.1	3.2	3.3	3.7	6.8	7	

Dimensions [mm]						
size	nominal diameter DN					
	15	20	25	32	40	50
A ₂	160	160	160	180	200	230
B	235	235	235	235	350	350
C	275	275	275	275	420	420
D	140	140	140	140	200	200
E	G 1/4	G 1/4	G 1/4	G 1/4	G 1/4	G 1/4

Weights [kg]						
nominal diameter DN						
15	20	25	32	40	50	
4.2	4.7	5	6	7.4	10.3	

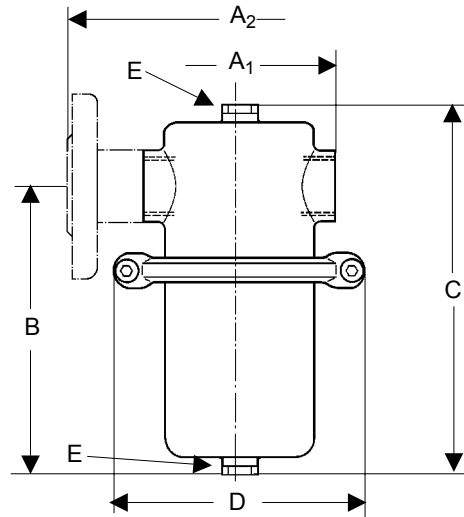

Special designs on request.
 The pressure has always been indicated as overpressure.
 Mankenberg reserves the right, to alter or improve the designs or specifications of the products described herein without notice.