

twin bleed valve float-controlled up to 130 °C  
for start-up and continuous operation



## Technical Data

Connection	DN 50 - 150
Nominal Pressure	PN 16
Operating Pressure	0 - 8 bar
Flow Rate	up to 1030 m <sup>3</sup> /h

## Description

Bleeding and venting valves remove air or gases from systems or pipelines without requiring an external energy input. When a system is drained they act as venting valves; venting may be prevented by fitting a check valve.

The EB 1.74 bleeding/venting valve is a combined start-up/continuous bleeding/venting valve with float control. During start-up a large volume of air is bled at low pressure via a large valve cone. When the bleed valve is closed and small air volumes have to be bled during continuous operation, an additional smaller cone in the valve opens and bleeds these smaller volumes. The large cone will not open until the liquid level and the pressure drops. The valve opens immediately if a vacuum forms.

The EB 1.74 bleeding/venting valve is a compact and lightweight float-controlled valve. It is manufactured from deep-drawn stainless steel featuring excellent corrosion resistance. The valve cone can be fitted with a soft or metallic seal. The minimum pressure required for valve sealing is 0.2 bar.

Top and bottom sections of the valve body are connected by a clamp ring and two bolts. Servicing/maintenance is easy and does not call for special tooling.

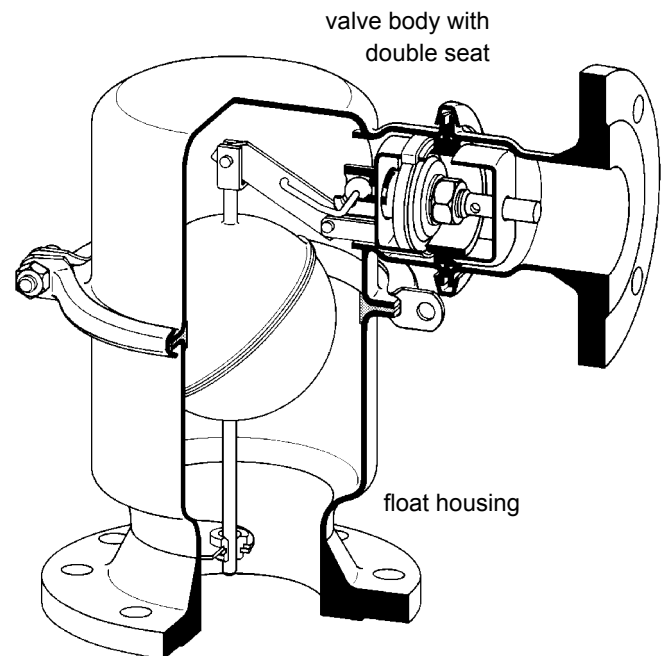

## STANDARD EQUIPMENT

- All stainless steel construction
- Quick-release body clamp ring

## OPTIONS

- Ozone-resistant design
- Various seal materials suitable for your medium
- Plastic coating for corrosive fluids
- Non-return valve to prevent venting
- Special connections: Aseptic, ANSI or DIN flanges, welding spigots; other connections on request
- Special versions on request

Please state working pressure range when enquiring or ordering.

Operating instructions, Know How and Safety instructions must be observed.

The pressure has always been indicated as overpressure.  
We reserve the right to alter technical specifications without notice.

Air Flow Rate [m <sup>3</sup> /h] at 0 °C, 1013 mbar						
	ΔP bar	Nennweite DN				
		50	65	80	100	150
start up venting	0.05	113	396	396	396	728
	0.1	159	560	560	560	1030
continuous venting	1	11	25	25	25	55
	2	16	38	38	38	85
	4	28	63	63	63	140
	6	39	88	88	88	209
	8	50	114	114	114	250

twin bleed valve float-controlled up to 130 °C  
for start-up and continuous operation



Materials	
Body	CrNiMo-steel
Body Seal	EPDM
Internals	CrNiMo-steel
Float	CrNiMo-steel
Valve Seal	EPDM + metallic
Profile Clamp	CrNiMo-steel

Dimensions [mm]					
size	nominal diameter DN				
	50 / 50	65 / 65	80 / 65	100 / 65	150 / 80
A	285	285	300	265	695
B	175	235	235	235	300
C	325	330	340	310	795
D	200	265	265	265	273
E	25	40	25	55	-

size A tolerance  $\pm 4$  mm

Weights [kg]					
nominal diameter DN					
50	65	80	100	150	
8.5	14.5	15	16	28	

Special designs on request.  
The pressure has always been indicated as overpressure.  
Mankenberg reserves the right, to alter or improve the designs or specifications of the products described herein without notice.

DN 50 - 100

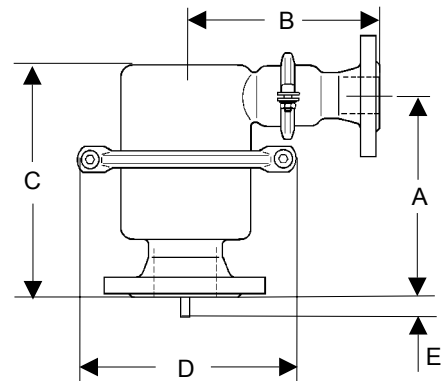

DN 150

