



Pressure reducer for liquids and gases up to 130°C, steam up to 180 °C  
CIP/SIP design for sanitary use

## Technical Data

Connection	DN 15 - 50 clamps other connections on request
Nominal Pressure	PN 2.5 - 10 (see table below)
Inlet Pressure	up to 8 bar
Outlet Pressure	0.3 - 5 bar in 3 setting ranges
K <sub>vs</sub> -Value	2 - 5.2 m <sup>3</sup> /h
Tightness	in acc. to VDI/VDE-guideline 2174 (leakage rate ≤ 0.05 % of K <sub>vs</sub> -value)

## Description

Medium-controlled pressure reducers are simple control valves offering accurate control while being easy to install and maintain. They control the pressure downstream of the valve without requiring pneumatic or electrical control elements.

The DM 152 pressure reducing valve is a diaphragm-controlled spring-loaded proportional control valve which is primarily used for hygienic applications in the food processing and pharmaceutical industries. A PTFE protective foil renders the diaphragm physiologically safe and steamproof up to 180 °C. The valve does not require an external pilot line.

This pressure reducer is manufactured from deep-drawn stainless steel featuring excellent corrosion resistance. It contains virtually no dead pockets and is suitable for use in CIP and SIP systems. The angled design allows complete draining.

The spring module comprising bonnet, spring, adjusting screw, diaphragm and internal components, is connected to the valve body only by means of a clamp ring and two bolts. Changing the diaphragm or the complete spring assembly for a different control pressure range is extremely simple and does not call for special tools. The same applies to servicing and maintenance. Changing the control pressure setting does not affect the height of the valve (non increasing adjusting screw).

The outlet pressure to be controlled is balanced across the diaphragm by the force of the valve spring (set pressure). As the outlet pressure rises above the pressure set using the adjusting screw, the valve cone moves towards the seat and the volume of medium is reduced. As the outlet pressure drops the valve control orifice increases; when the pipeline is depressurised the valve is open. Rotating the adjusting screw clockwise increases the outlet pressure.

## STANDARD EQUIPMENT

- All stainless steel construction
- Non increasing adjusting screw
- Quick-release body clamp ring
- Diaphragm protected by PTFE foil

## OPTIONS

- Polished version for food, pharmaceutical and superclean applications, surface roughness Ra ≤ 0.25 or 0.4 or 0.8 µm
- Metal diaphragm
- soft seal
- For toxic or hazardous media: sealed bonnet complete with leakage line connection (incl. sealed adjusting screw). Must be installed with a leakage line capable of draining leaking medium safely and without pressure
- Various diaphragm and seal materials suitable for your medium
- Special connections: Aseptic, ANSI or DIN flanges, welding spigots; other connections on request
- Special versions on request

Operating instructions, Know How and Safety instructions must be observed.

All the pressure has always been indicated as overpressure.  
We reserve the right to alter technical specifications without notice.

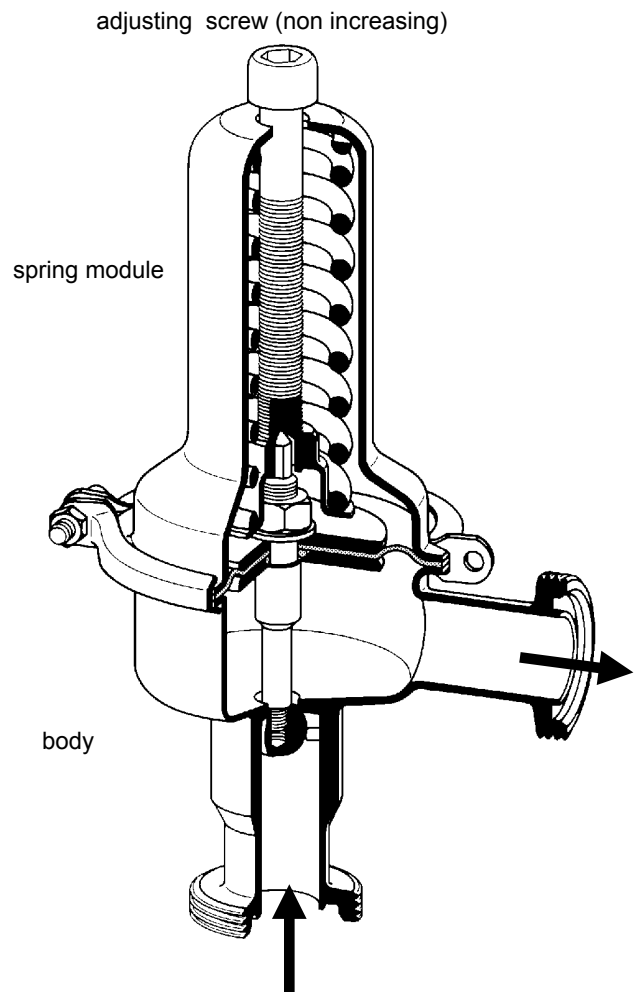

K <sub>vs</sub> -Values [m <sup>3</sup> /h]		15	20	25	32	40	50
nom. diam.	DN	15	20	25	32	40	50
K <sub>vs</sub> -value	m <sup>3</sup> /h	2	3	3.5	4	4.5	5.2

Setting Ranges [bar] and Nominal Pressure PN				
outlet press.	bar	1 - 5	0.8 - 2.5	0.3 - 1.1
nom. diam.		15 - 50	15 - 50	15 - 50
PN		10/10	10/6	10/2.5

Pressure reducer for liquids and gases up to 130°C, steam up to 180 °C  
CIP/SIP design for sanitary use



Materials	
Body, Bonnet, Internals	CrNiMo-steel
Spring	CrNi-steel
Valve Seal	CrNiMo-steel optional soft seal
Diaphragm	FPM
Protection Foil (for diaphragm)	PTFE

Dimensions [mm]							
pressure range [bar]	size	nominal diameter DN					
		15	20	25	32	40	50
0.8-2.5 2-5	AE <sub>1</sub>	90	90	90	120	120	120
	AE <sub>2</sub>	90 / 100 / 110 *		90	120	120	120
	C	200	200	200	200	200	200
	D	138	138	138	138	138	138

\* size can vary according to type of connection, please inquire

Dimensions [mm]							
pressure range [bar]	size	nominal diameter DN					
		15	20	25	32	40	50
0.3-1.1	AE <sub>1</sub>	120	120	120	120	120	120
	AE <sub>2</sub>	120 / 140 *		120	120	120	120
	C	200	200	200	200	200	200
	D	200	200	200	200	200	200

\* size can vary according to type of connection please inquire

Weights [kg]						
pressure range [bar]	nominal diameter DN					
	15	20	25	32	40	50
0.8 - 2.5	2	2	2	2.5	2.5	3
1 - 5	2	2	2	2.5	2.5	3
0.3 - 1.1	3	3	3	3.5	3.5	4

Special designs on request.

The pressure has always been indicated as overpressure.

Mankenberg reserves the right, to alter or improve the designs or specifications of the products described herein without notice.

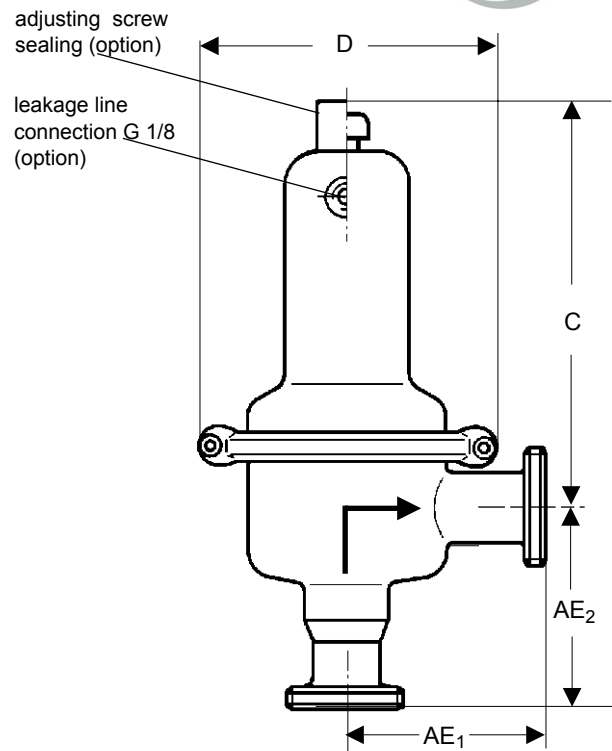

### Recommended installation

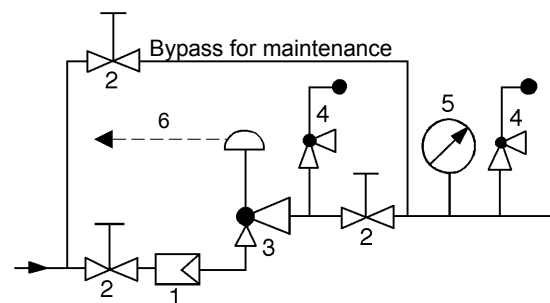

- 1 Strainer
- 2 Shutoff valves
- 3 Pressure reducer
- 4 Safety valve
- 5 Pressure gauge
- 6 Leakage line G 1/8 (option)

use MANKENBERG-products