

Klapy zwrotne art. 02



Tabela wymiarów¹

- DN 40 – DN 400 PN 10 – PN 25, ANSI-125

DN		Wymiary w mm							
mm	"	A			B	C	E	F	G
		PN-10/16	PN-25	ANSI-125					
40	1 1/2	94	94	-	43 ²	58	18	33	14
50	2	108	108	104	43	58	12	33	22
65	2 1/2	128	128	124	46	58	12	33	25
80	3	143	143	136	64	71	18	41	33
100	4	163	163	166	64	96	28	52	26
125	5	194	194	194	70	125	35	70	33
150	6	219	219	219	76	128	33	70	35
200	8	275	284	275	89	192	60	104	36
250	10	329	338	338	114	244	81	126	48
300	12	380	402	408	114	295	100	153	49
350	14	440	458	450	127	320	108	168	54
400	16	490	514	514	140	380	137	195	58

- DN 50 – DN 300 PN 40, ANSI-150

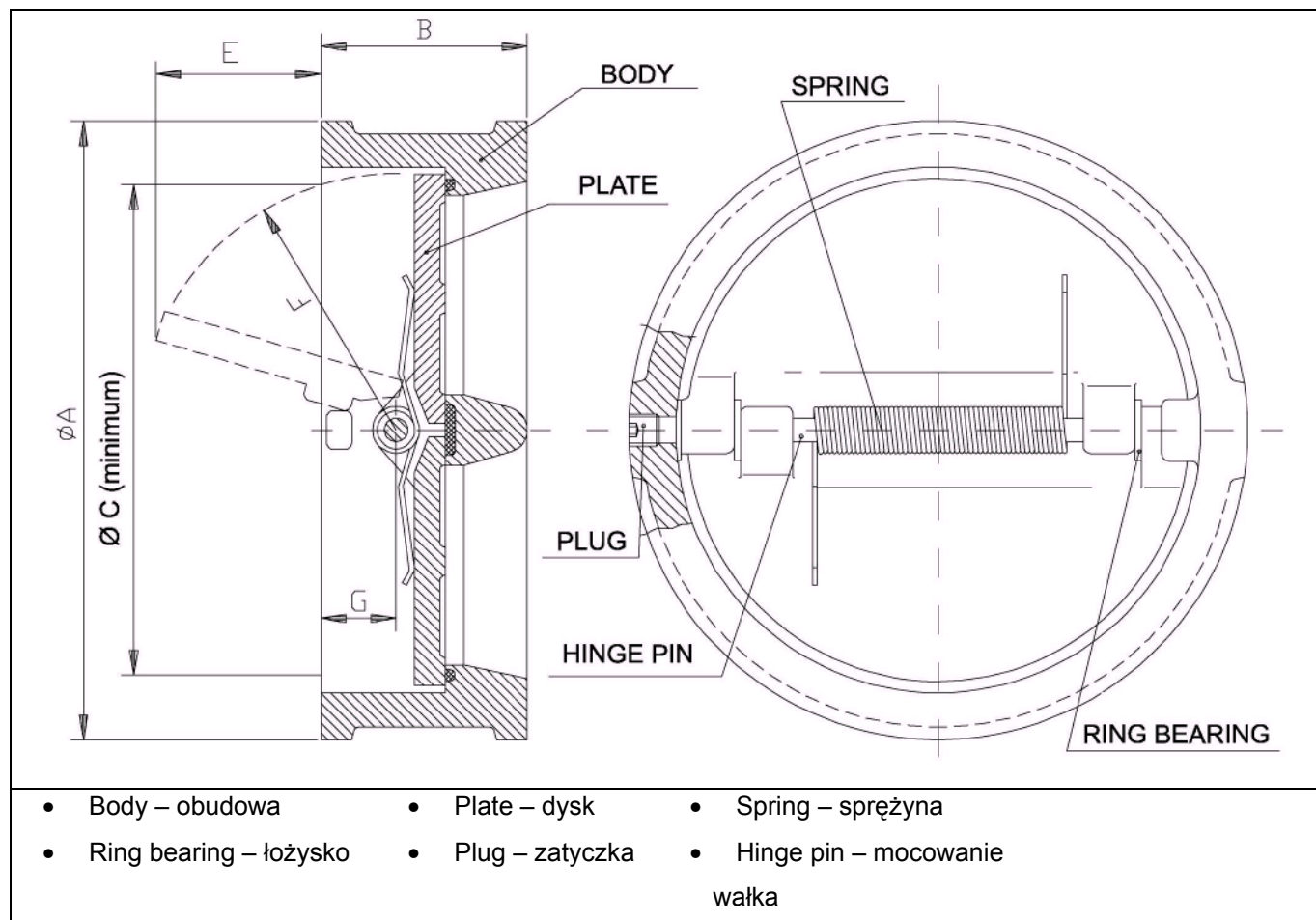
DN		Wymiary w mm						
mm	"	A		B	C	E	F	G
		A-150	PN-40					
40	1 1/2	-	94	43	58	12	33	22
50	2	104	108	43	58	12	33	22
80	3	136	143	64	71	18	41	33
100	4	169	169	64	96	28	52	26
125	5	194	194	70	125	35	70	33
150	6	219	224	76	128	33	70	35
200	8	275	293	89	192	60	104	36
250	10	338	355	114	244	81	126	48
300	12	408	419	114	295	100	153	49

¹ Długość zabudowy DIN-3202 (K-3), ISO-5752

² Nieznormalizowana długość zabudowy

- **DN 450 – DN 600 PN 10/16, ANSI-125**

DN		Wymiary w mm							
mm	"	A			B	C	E	F	G
		PN-10	PN-16	ANSI-125					
450	18	540	556	543	152	420	152	217	65
500	20	595	618	605	152	480	175	247	65
600	24	696	735	716	178	585	222	299	77

- **DN 700 – DN 1200 PN 10/16, ANSI-125/150**

DN		Wymiary w mm							
mm	"	A			B	C	E	F	G
		PN-10	PN-16	ANSI-125					
700	28	810	810	830	229	690	250	352	103
800	32	915	915	937	241	780	290	395	107
900	36	1015	1015	1046	241	850	332	445	112
1000	40	1124	1124	1216	300	940	332	483	152
1200	48	1340	1340	1380	350	1150	442	601	159