

Pressure Control Valves DM 603

Pressure Reducing Valves

Standard Cast Valve



Technical Data

Connection DN	15 - 150
Nominal Pressure PN	16 - 40
Inlet Pressure	up to 40 bar
Outlet Pressure	0.02 - 10 bar
K _{vs} -Value	4 - 160 m ³ /h
Temperature	350 °C
Medium	steam

Description

Medium-controlled pressure reducers are simple control valves offering accurate control while being easy to install and maintain. They control the pressure downstream of the valve without requiring pneumatic or electrical control elements.

The DM 603 pressure reducing valve is a diaphragm-controlled spring-loaded proportional control valve for high temperatures and large volumes. The valve cone is fitted with a metallic seal (up to 350 °C).

The outlet pressure to be controlled is balanced across the diaphragm by the force of the valve spring (set pressure). As the outlet pressure rises above the pressure set using the adjusting screw, the valve cone moves towards the seat and the volume of medium is reduced. As the outlet pressure drops the valve control orifice increases; when the pipeline is depressurised the valve is open. Rotating the adjusting screw clockwise increases the outlet pressure.

The valves requires a pilot line (to be installed on-site).

These valves are no shut-off elements ensuring a tight closing of the valve. In accordance with the VDI/VDE guideline 2174 a leakage rate of 0.05 percent of the constant volume flow is permitted for the valve in closed position.

Standard

- » open spring
- » pilot line connection

Options

- » sealed bonnet
- » for toxic or hazardous media: sealed bonnet complete with leakage line connection (incl. sealed adjusting screw). Must be installed with a leakage line capable of draining leaking medium safely and without pressure
- » various diaphragm and seal materials suitable for your medium
- » special versions on request

Operating instructions, Know How and Safety instructions must be observed. All the pressure has always been indicated as overpressure. We reserve the right to alter technical specifications without notice.



ill. similar

K_{vs}-Values [m³/h]

DN	15	20	25	40	50	65	80	100	125	150
m ³ /h	4	5	6	20	32	50	80	100	140	160

Setting Ranges [bar]

DN 15-50	0.02 - 0.25	0.1 - 0.6	0.2 - 1.2	0.8 - 2.5	2 - 5	4.5 - 10
DN 65-100	0.02 - 0.25	0.1 - 0.6	0.2 - 1.2	0.8 - 2.5	2 - 5	4 - 8
DN 125+150	0.05 - 0.25	0.1 - 0.6	0.2 - 1.2	0.8 - 2.5	2 - 3.5	2 - 5
PN	40/1	40/1	40/2.5	40/6	40/10	40/16

Pressure Control Valves DM 603

Pressure Reducing Valves

Standard Cast Valve



Materials		
Temperature		350 °C
Body	PN 16	up to DN 25 grey cast iron, from DN 40 spheroidal cast iron
	PN 25 /40	cast steel
	PN 16 - 40	CrNiMo-steel
Diaphragm Housing		steel welded optional CrNiMo-steel
Bonnet		steel welded optional CrNiMo-steel
Spring		spring steel C optional CrNi-steel
Diaphragm		EPDM
O-Ring (balance)		EPDM

Dimensions [mm]											
size	pressure range bar	nominal diameter DN									
		15	20	25	40	50	65	80	100	125	150
A	0.02-5/8/10	130	150	160	200	230	290	310	350	400	480
B		55	55	55	75	75	105	105	105	220	220
C	4.5 - 8/10	690	690	690	830	930	880	880	880	1040	1040
C ₁	2 - 3.5/5	820	820	820	990	990	1040	1040	1040	1200	1200
D	0.8 - 2.5	175	175	175	220	220	220	220	220	220	220
C	0.2 - 1.2	710	710	710	830	830	880	880	880	940	940
C ₁		840	840	840	990	990	1040	1040	1040	1100	1100
D		220	220	220	270	270	270	270	270	270	270
C	0.1 - 0.6	710	710	710	830	830	880	880	880	940	940
C ₁		840	840	840	990	990	1040	1040	1040	1100	1100
D		270	270	270	360	360	360	360	360	360	360
C	0.02 / 0.05 - 0.25	710	710	710	710	710	760	760	760	940	940
C ₁		840	840	840	870	870	920	920	920	1100	1100
D		360	360	360	360	360	360	360	360	500	500

Weights [kg]											
nom. pressure	pressure range bar	nominal diameter DN									
		15	20	25	40	50	65	80	100	125	150
PN 16	0.8 - 5/8/10	18	18	19	33	36	61	64	68	110	130
	0.2 - 1.2	20	20	21	35	38	63	66	70	112	132
	0.1 - 0.6	24	24	25	39	42	67	70	74	116	136
	0.02/0.05-0.25	24	24	25	37	40	65	68	72	122	142
PN 25/40	0.8 - 5/8/10	19	19	20	36	38	64	68	71	118	143
	0.2 - 1.2	21	21	22	38	40	66	70	73	120	145
	0.1 - 0.6	25	25	26	42	44	70	74	77	124	149
	0.02/0.05-0.25	25	25	26	40	42	68	72	75	130	155

Special designs on request.
The pressure has always been indicated as overpressure.
Mankenberg reserves the right, to alter or improve the designs or specifications of the products described herein without notice.

Dimensional Drawing

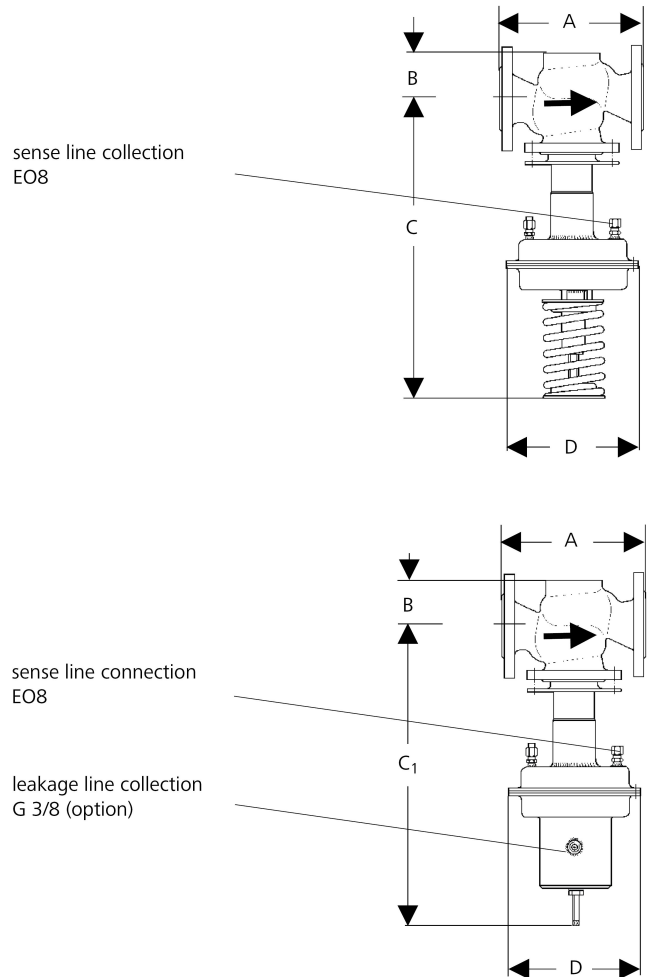

Recommended Installation

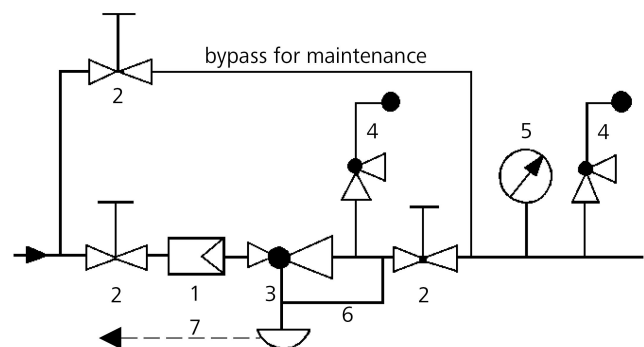

- 1 Strainer
- 2 Shut-off Valves
- 3 Pressure Reducer
- 4 Safety Valves
- 5 Pressure Gauge
- 6 Sense Line EO8
- 7 Leakage Line G 3/8 (option)

sense line connection 10 - 20 x DN behind the valve
use MANKENBERG-Products